



## QUICK RELEASE BATTERY TRAY — QRBT KIT RV8

### INSTALLATION IN FLEX INNOVATIONS RV-8

#### Tools and Materials required to complete

- Double sided tape
- Filament reinforced tape
- 1/8" or 3.2mm drill bit
- 2.5mm hex wrench or driver

#### Retainer Installation

0. Review the exploded drawing on the back side of this sheet for the parts and part names that will be used during installation.
1. Position the LiPo flight pack at the desired location on the plywood deck inside the fuselage. Mark the aft end of the pack. This will be the reference point for the aft end of the Retainer.
2. Remove factory installed hook and loop straps.
3. Using the paper template included in the kit, cut on the dotted lines and place the template on the plywood deck. Align the aft end of the template with the mark made in Step 1.
4. Carefully center punch the template at the six drill locations. Do not drill through the template. It will tear and make precise drilling impossible.
5. Remove the paper template from the deck and, using a 1/8" or 3.2mm drill bit, drill through the six locations center punched in Step 4.
6. Locate the Retainer and place it on the plywood deck aligning the slots in the Retainer with the holes drilled in Step 5.
7. Locate the six M3 x 16 socket head screws and flat washers. Place a washer on each screw.
8. Locate the two Nut Strips and the six Nylock nuts in the kit. Press the Nylock nuts into the recesses in the Nut Strips
9. Starting from the aft end of the plywood deck, near the wing tube location, slide one Nut Strip under the plywood deck. The nuts should be on the bottom side of the Nut Strip.
10. Insert one M3 x 16 screw from Step 7 through a slot in the Retainer, through the hole in the plywood deck and into the matching hole in the Nut Strip. Finger tighten only.

11. Repeat the actions in step 10 until all six M3 screws have been installed.
12. Align the aft end of the Retainer with the mark made in Step 1 and tighten all six M3 screws.

#### Mounting Flight Pack On Battery Tray

13. With the Retainer Installation complete, place the Battery Tray on top of the Retainer and align the tabs on the Tray with the rectangular notches in the sides of the Retainer so that the Tray sits on the plywood deck. Holding the Release Tabs on the Battery Tray, slide the Tray forward until the Tray 'clicks' into position. Check that the Tray is secure in the Retainer.
14. Place the flight pack on top of the Battery Tray and align the aft end of the flight pack with the aft end of the Retainer. Mark the position of the flight pack on the Battery Tray. Remove the pack and Tray from the Retainer.
15. Apply double-sided tape to the raised area of the Battery Tray then place the LiPo flight pack onto the Tray taking care to align the aft end of the pack with the mark made in Step 14.
16. Secure the pack to the battery tray by wrapping two single layer strips of filament-reinforced tape around the pack and the Tray. Locate the strips of tape between the tabs on the sides of the Tray. Make sure that only a single layer of tape is on the bottom of the tray. Make any overlaps of the tape on the top or sides of the pack. **IMPORTANT: MAKE SURE FILAMENT TAPE IS ONLY AROUND THE RAISED AREA OF THE BATTERY TRAY AND DOES NOT TOUCH THE RELEASE TABS. THEY MUST BE FREE TO BEND.**
17. Install the pack and Tray in the Retainer and check the CG of the model. Adjust the location of the Retainer as needed.

M3 socket head screws engage Nylock nuts in Nut Strips to 'clamp' Retainer to plywood deck

RETAINER

'Spring end' of Battery Tray presses against end of Retainer, holding catches in place until Release Tabs are squeezed

BATTERY TRAY

NUT STRIP

Raised area of Tray allows lighter packs to be mounted forward, overhanging Spring end of Tray while heavier packs are mounted aft of Spring end

M3 Nylock nuts are pressed into recesses on underside of Nut Strip

Squeezing Release Tabs together releases catches allowing Tray to slide out.

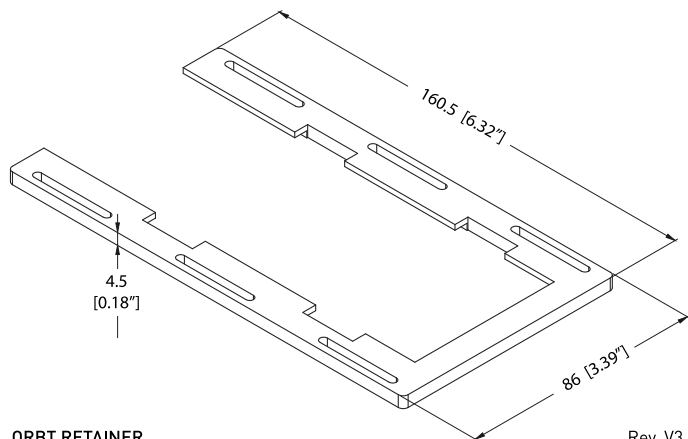

QRBT RETAINER

Rev. V3

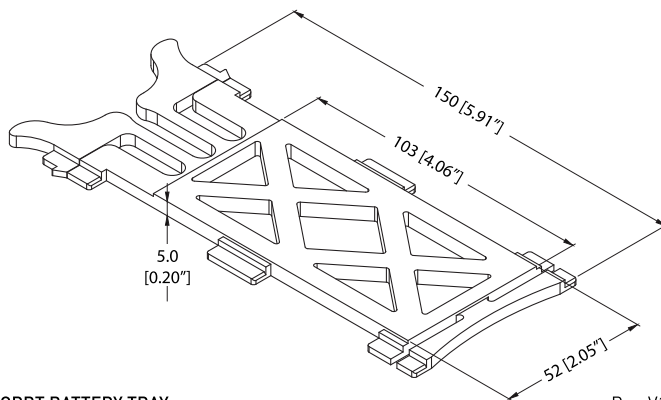

QRBT BATTERY TRAY

Rev. V12

